

RA-920

RESISTANCE ATTENUATOR

INSTRUCTION MANUAL

You are now the owner of our new product RA-920. This unit has been carefully engineered and manufactured under our rigid quality control and should give you satisfactory and dependable operation for many years. If trouble is encountered or the unit is damaged in transit, please contact your dealer or the nearest service station.

CONTENTS

Features	3
Specifications	3
Circuit Description	4
Control Panel	5
Cautions	7
Applications	8
Parts List	11
P.C. Board	17
Schematic Diagram	19

FEATURES

- * Accurate attenuation over a wide range from DC to 1 MHz.
- * Metallic film resistors are used throughout the circuitry to provide excellent temperature characteristic and accurate attenuation accuracy.
- * Adoption of phase compensation eliminates phase deviation in high frequencies, permitting attenuation of pulse signals.
- * Since the case is of the floating ground system, the unit can be readily connected to an electronic device having a different case potential. By grounding the case, the measurement accuracy is further improved.
- * Rotary switches are used for easy dial setting.

SPECIFICATIONS

Frequency Range:	DC-1 MHz
Attenuation Range:	0-121 dB (0.1 dB step)
Input/Output Impedance:	600 ohm, ± 10 ohm
Maximum Input Level:	+27 dBm or 0.5W or 17Vrms
Attenuation Accuracy(1kHz):	
	Less than ± 0.2 dB
	Less than ± 0.1 dB for 1 dB step range
	Less than ± 0.01 dB for 0.1 dB step range
Frequency Characteristic (reference freq. 1 kHz)	
	DC-80 kHz: ± 0.2 dB (0-121 dB)
	DC-100 kHz: ± 0.2 dB (0-100 dB)
	DC-150 kHz: ± 0.5 dB (0-100 dB)
	DC-150 kHz: ± 1 dB (0-121 dB)
	DC-1 MHz: ± 1.5 dB (0-60 dB)
Maximum Floating Voltage:	
	(DC+AC peak): ± 600 V
Ambient Temperature:	$23^{\circ}\text{C} \pm 10^{\circ}\text{C}$
Operating Temperature:	$0^{\circ}\text{C} - 50^{\circ}\text{C}$
Dimensions:	335(W) x 87(D) x 105(H)mm
Weight:	2 kg
Accessories:	
	Instruction manual 1
	Shorting bar 1
	Cover (option) Standard
	Accessory for RA-920(A)

CIRCUIT DESCRIPTION

1. Outline of Circuit

Fig. 1 shows the block diagram of the circuit. The large attenuation ranges use "T" or double "T" network and the small attenuation ranges use Bridge "T" networks. Each step has 600 ohm impedance and is provided with capacitors for phase compensation.

2. "T", Double "T" and Bridge "T" Networks

The "T" network is used in the circuit where the attenuation per step is large, while the double "T" network is used where the attenuation per step exceeds 40 dB so that the effect of stray capacitance is minimized

and the accuracy is further improved.

Accordingly, when the attenuation per step is 60 dB, the error caused by a single stage "T" network is $\pm 60 \epsilon$ dB, but can be reduced to $\pm 42 \epsilon$ dB (see NOTE below) if it is divided into two stages.

$$\text{NOTE: } \pm \sqrt{(30 \epsilon)^2 + (30 \epsilon)^2} \approx \pm 42 \epsilon \text{ dB,}$$

where the accuracy of resistors is $\pm \epsilon$ (%).

The bridge "T" network is used in the circuit from which small attenuations are obtained. The reason for the use of this network is to reduce the number of resistors.

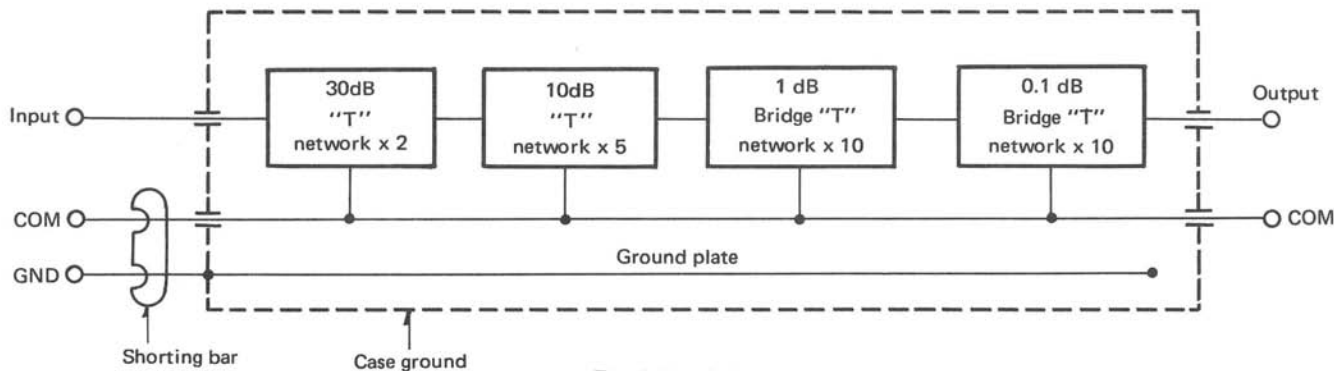

Fig. 1 Block Diagram

CONTROL PANEL

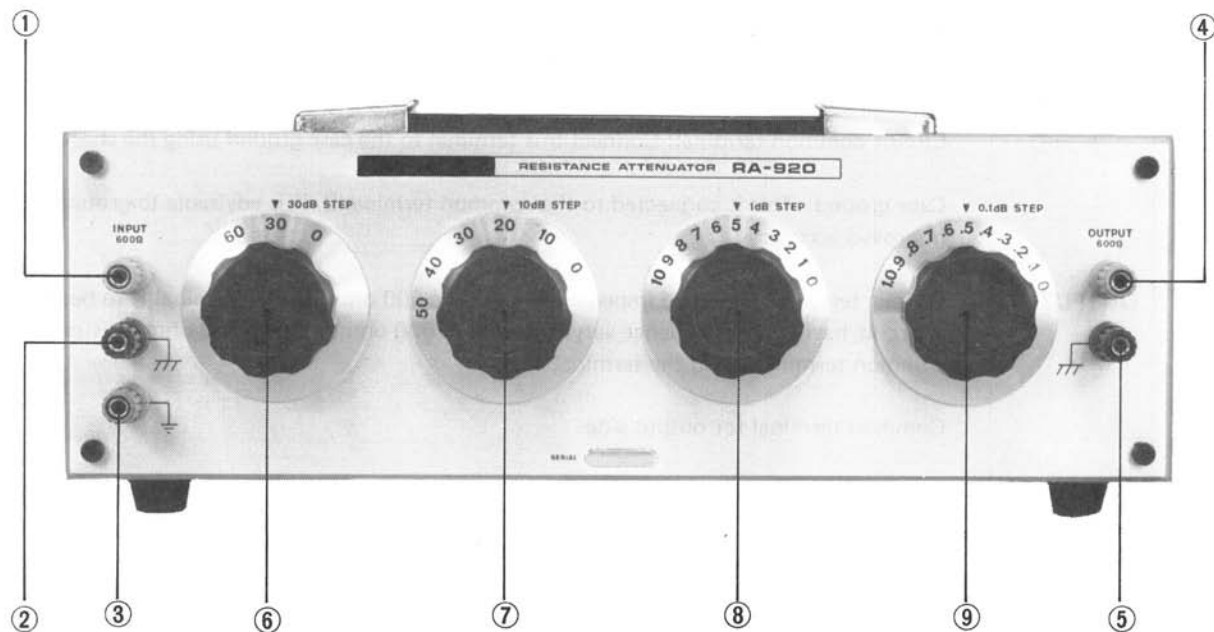





Fig. 2

CONTROL PANEL

Reference No.	Marking	Descriptions
1	INPUT	Input terminal: Connect a shielded cable or coaxial cable between the signal source and this terminal. The cable length should not exceed 1 m.
2		Circuit common terminal: Connect this terminal to the case ground using the shorting bar.
3		Case ground: This is connected to the common terminal 2. It is advisable to ground the case for improved accuracy.
4	OUTPUT	Output terminal: The load impedance should be 600 ohm. If this terminal is to be connected to a circuit having an impedance very higher than 600 ohm, insert a 600 ohm resistor between the common terminal 5 and the terminal 4.
5		Common terminal for output side.
6	30 dB STEP	Dial for 0-30-60 dB attenuation.
7	10 dB STEP	Dial for 0-10-20-30-40-50 dB attenuation.
8	1 dB STEP	Dial for setting attenuations of 0 to 10 dB in 1 dB step.
9	0.1 dB STEP	Dial for setting attenuations of 0 to 1.0 dB in 0.1 dB step.

CAUTIONS

1. The signal voltage applied to INPUT should be lower than 17 Vrms.
2. To avoid leakage of signal and minimize the effect of phase deviation, be sure to use shielded cables on the input and output of the unit. These cables should be as short as possible. This is particularly important when pulse signals are used as a signal source.
3. When the unit is used with the case ground floated from the circuit ground, the potential difference (DC + AC peak) between these two points should not exceed $\pm 600V$.

4. Dial setting

Select appropriate dials for the desired attenuation at any frequency. Note that the markings on each dial indicate approximate settings of attenuation including error. A typical example of attenuation error and frequency characteristic error is shown in Table 1, where 100 kHz signal is attenuated to 100 dB, ϵ_a is the error at 1 kHz of each dial and ϵ_f is the error of frequency characteristic.

The overall error depends on the number of dials to be used as explained below.

- I) When the dials are set to 30 dB x 2 = 60 dB, 10 dB x 3 = 30 dB, 1 dB x 9 = 9 dB and 0.1 dB x 10 = 1 dB, then the overall error (ϵ) caused by each dial and frequency characteristic is obtained from the follow-

ing equation:

$$\epsilon = \pm \sqrt{(0.15^2 + 0.1^2) + (0.1^2 + 0.1^2) + (0.1^2 + 0.05^2) + (0.01^2 + 0.05^2)} = \pm 0.28 \text{ dB}$$

- II) When the dials are set to 30 dB x 2 = 60 dB, 10 dB x 4 = 40 dB, then:

$$\epsilon = \pm \sqrt{(0.15^2 + 0.1^2) + (0.1^2 + 0.1^2)} = 0.23 \text{ dB}$$

As will be understood from the above equations, the less the number of dials, the higher the accuracy.

Table 1. Typical Example of Attenuation Error and Frequency Characteristic Error

Error	30 dB step	10 dB step	1 dB step	0.1 dB step
ϵ_a	$\pm 0.15 \text{ dB}$	$\pm 0.1 \text{ dB}$	$\pm 0.1 \text{ dB}$	$\pm 0.01 \text{ dB}$
ϵ_f	$\pm 0.1 \text{ dB}$	$\pm 0.1 \text{ dB}$	$\pm 0.05 \text{ dB}$	$\pm 0.05 \text{ dB}$

APPLICATIONS

1. Measurement of amplifier gain

Example: Audio frequencies, 455 kHz IF frequency, pulse amplifier, etc.

Connect an oscillator, RA-920, amplifier to be tested and AC voltmeter (DC voltmeter for DC amplifier) using switches sufficiently durable against frequencies and currents, as shown in Fig. 3. Set the load impedance of RA-920 to 600 ohm.

- 1) Set RA-920 to 0 dB (may be attenuated to a certain level depending on the condition of oscillator).
- 2) Set the switches to the B position and read the indication of the voltmeter.
- 3) Next, set the switches to the A position. Adjust RA-920 so that the reading on the voltmeter is the same as at the B position. The reading obtained is the gain of the amplifier.

When a DC amplifier is to be tested, be sure that the input level does not exceed the maximum input voltage of the amplifier. Note that if the input impedance of DC amplifier, etc. is lower than 600 ohm, the error becomes larger.

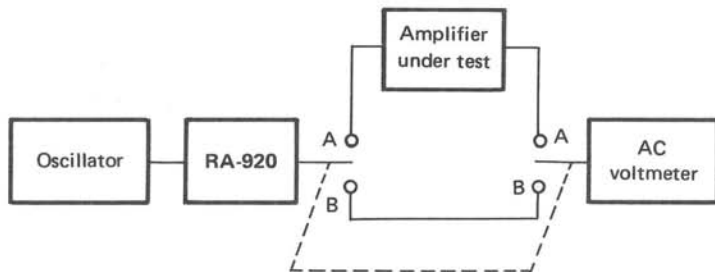

Fig. 3

APPLICATIONS

2. Measurement of pulse circuit threshold level (Fig. 4)

- 1) Adjust the voltage of pulse circuit to a proper level (5-10V for TTL), then set RA-920 to 0 dB.
- 2) Adjust RA-920 so that the output disappears from the oscilloscope.
- 3) Where the reading of RA-920 is δ , the threshold level is e_0 , and the pulse generator output is e_i ,

$$e_0 = e_i \times \text{LOG}^{-1} \frac{\delta}{20}$$

In measurement, be sure that the pulse frequency is below 100 kHz, the signal is properly shielded and the load impedance is adequate.

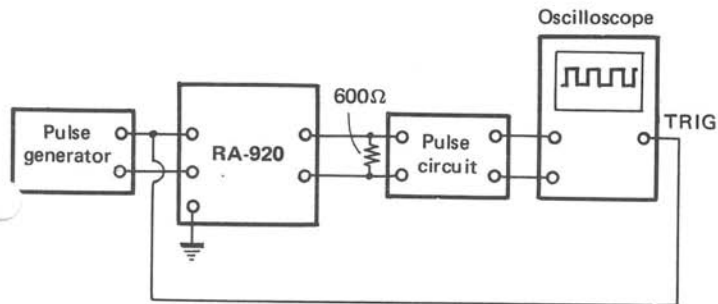

Fig. 4

3. Audio mixing (Fig. 5)

By using two RA-920, it is possible to attenuate two individual signals for audio mixing.

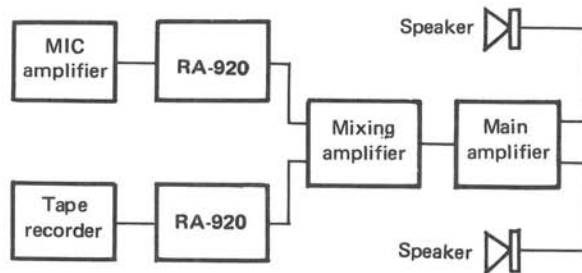

Fig. 5

APPLICATIONS

4. Measurement of noise (Fig. 6)

If the noise indices of A and B are expressed by F_1 and F_3 respectively, the amount of attenuation is expressed by L_2 , and the gain G_1 of A is sufficiently large,

$$F_1 \doteq \frac{Rt_1 L_2'' - Ft_2 L_2'}{L_2'' - L_2'} \quad (F_1 \gg \frac{1}{G})$$

F_{t1} and F_{t2} are F_t (overall noise figure) where L_2 is L_2' and L_2''

Measurement of noise should be performed after checking the circuit system.

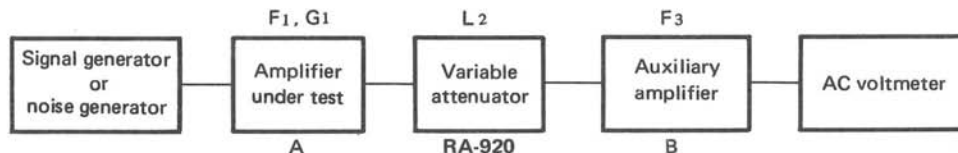

Fig. 6

PARTS LIST OF RA-920

SCHEMATIC SYMBOL	PARTS NO.	DESCRIPTION
	A01-0813-02	Case
	A21-0815-13	Panel
	B40-0765-14	Name plate
	B42-1933-04	Label
	B50-2828-10	Instruction manual
	C91-0505-05	Oil capacitor 0.0047 μ F
	E23-0507-03	Grounding plate
	E21-0150-03	Terminal (grey) \times 2
	E21-0151-03	Terminal (orange) \times 2
	E21-0653-03	Terminal (blue)
	E29-0506-04	Shorting bar
	H01-2817-14	Packing case (individual packing)
	H12-0514-02	Packing material, foamed styrene \times 2
	H25-0825-04	Polyethylene bag
	J02-0503-15	Rubber leg \times 8
	K01-0058-25	Grip
	K21-0808-03	Knob, for 30 dB step attenuator
	K21-0809-03	Knob, for 10 dB step attenuator
	K21-0810-03	Knob, for 1 dB step attenuator
	K21-0811-03	Knob, for 0.1 dB step attenuator
	X75-1050-00	30 dB step unit
	X75-1060-00	10 dB step unit
	X75-1070-00	1 dB step unit
	X75-1080-00	0.1 dB step unit

PARTS LIST OF X75-1050-00

SCHMATIC SYMBOL	PARTS NO.	DESCRIPTION
		RESISTOR
R401	R92-0734-05	Metal film 563.2 Ω \pm 0.5% 1/2W
R402	R92-0733-05	Metal film 37.99 Ω \pm 0.5% 1/2W
R403, 404	R92-0734-05	Metal film 563.2 Ω \pm 0.5% 1/2W
R405	R92-0733-05	Metal film 37.99 Ω \pm 0.5% 1/2W
R406	R92-0735-05	Metal film 1,126 k Ω \pm 0.5% 1/2W
R407	R92-0733-05	Metal film 37.99 Ω \pm 0.5% 1/2W
R408	R92-0734-05	Metal film 563.2 Ω \pm 0.5% 1/2W
		CAPACITOR
C402	CM93BD2A132J	Mica 1,300pF \pm 10%
		MISCELLANEOUS
	J25-2819-04	Printed circuit board
S401 a, b	S01-1502-05	Rotary switch

PARTS LIST OF X75-1060-00

SCHMATIC SYMBOL	PARTS NO.	DESCRIPTION
		RESISTOR
R301	R92-0728-05	Metal film 311.7 Ω \pm 0.5% 1/2W
R302	R92-0729-05	Metal film 421.6 Ω \pm 0.5% 1/2W

SCHEMATIC SYMBOL	PARTS NO.	DESCRIPTION
R303 R304 R305 R306 R307 R308 R309 R310 R311 R312 R313 R314, 315 R316 R317 R318 R319	R92-0728-05 R92-0730-05 R92-0727-05 R92-0730-05 R92-0734-05 R92-0733-05 R92-0734-05 R92-0730-05 R92-0727-05 R92-0731-05 R92-0727-05 R92-0730-05 R92-0727-05 R92-0732-05 R92-0733-05 R92-0734-05	Metal film 311.7 Ω \pm 0.5% 1/2W Metal film 490.9 Ω \pm 0.5% 1/2W Metal film 121.2 Ω \pm 0.5% 1/2W Metal film 490.9 Ω \pm 0.5% 1/2W Metal film 563.2 Ω \pm 0.5% 1/2W Metal film 37.99 Ω \pm 0.5% 1/2W Metal film 563.2 Ω \pm 0.5% 1/2W Metal film 490.9 Ω \pm 0.5% 1/2W Metal film 121.2 Ω \pm 0.5% 1/2W Metal film 981.8 Ω \pm 0.5% 1/2W Metal film 121.2 Ω \pm 0.5% 1/2W Metal film 490.9 Ω \pm 0.5% 1/2W Metal film 121.2 Ω \pm 0.5% 1/2W Metal film 1.054k Ω \pm 0.5% 1/2W Metal film 37.99 Ω \pm 0.5% 1/2W Metal film 563.2 Ω \pm 0.5% 1/2W
C305	CM93BD2A471J	<p style="text-align: center;">CAPACITOR</p> Mica 470pF \pm 10%
S301 a, b	J25-2820-04 S01-1503-05	<p style="text-align: center;">MISCELLANEOUS</p> Printed circuit board Rotary switch

PARTS LIST OF X75-1070-00

SCHEMATIC SYMBOL	PARTS NO.	DESCRIPTION
RESISTOR		
R201	RN14BK2H73R2F	Metal film 73.2Ω ±1% 1/2W
R202	RN14BK2H82R5F	Metal film 82.5Ω ±1% 1/2W
R203	RN14BK2H93R1F	Metal film 93.1Ω ±1% 1/2W
R204	RN14BK2H1020F	Metal film 10.2Ω ±1% 1/2W
R205	RN14BK2H1150F	Metal film 115Ω ±1% 1/2W
R206	RN14BK2H1300F	Metal film 130Ω ±1% 1/2W
R207	RN14BK2H1470F	Metal film 147Ω ±1% 1/2W
R208	RN14BK2H1650F	Metal film 165Ω ±1% 1/2W
R209	RN14BK2H1820F	Metal film 182Ω ±1% 1/2W
R210	RN14BK2H2050F	Metal film 205Ω ±1% 1/2W
R211	RN14BK2H2611F	Metal film 2.61Ω ±1% 1/2W
R212	RN14BK2H8660F	Metal film 866Ω ±1% 1/2W
R213	RN14BK2H4320F	Metal film 432Ω ±1% 1/2W
R214	RN14BK2H2550F	Metal film 255Ω ±1% 1/2W
R215	RN14BK2H1690F	Metal film 169Ω ±1% 1/2W
R216	RN14BK2H1180F	Metal film 118Ω ±1% 1/2W
R217	RN14BK2H86R6F	Metal film 86.6Ω ±1% 1/2W
R218	RN14BK2H66R5F	Metal film 66.5Ω ±1% 1/2W
R219	RN14BK2H53R6F	Metal film 53.6Ω ±1% 1/2W
R220	R92-0791-05	Metal film 277Ω ±0.5% 1/2W
R221, 222	R92-0792-05	Metal film 600Ω ±0.5% 1/2W
CAPACITOR		
C201, 202	CM93BD2A201J	Mica 200pF ±5%
C203	CM93BD2A330J	Mica 33pF ±5%
C204	CM93BD2A101J	Mica 100pF ±5%

SCHEMATIC SYMBOL	PARTS NO.	DESCRIPTION
S201 a,b	J25-2821-04	MISCELLANEOUS
	S01-1504-04	Printed circuit board Rotary switch

PARTS LIST OF X75-1080-00

SCHEMATIC SYMBOL	PARTS NO.	DESCRIPTION
RESISTOR		
R101	RN14BK2H6R98F	Metal film 6.98 Ω \pm 1% 1/2W
R102	RN14BK2H14R0F	Metal film 14.0 Ω \pm 1% 1/2W
R103	RN14BK2H21R5F	Metal film 21.5 Ω \pm 1% 1/2W
R104	RN14BK2H28R7F	Metal film 28.7 Ω \pm 1% 1/2W
R105	RN14BK2H36R5F	Metal film 36.5 Ω \pm 1% 1/2W
R106	RN14BK2H44R2F	Metal film 44.2 Ω \pm 1% 1/2W
R107	RN14BK2H51R1F	Metal film 51.1 Ω \pm 1% 1/2W
R108	RN14BK2H59R0F	Metal film 59.0 Ω \pm 1% 1/2W
R109	RN14BK2H68R1F	Metal film 68.1 Ω \pm 1% 1/2W
R110	RN14BK2H76R8F	Metal film 76.8 Ω \pm 1% 1/2W
R111	RN14BK2H2612F	Metal film 26.1k Ω \pm 1% 1/2W
R112	RN14BK2H8661F	Metal film 8.66k Ω \pm 1% 1/2W
R113	RN14BK2H4321F	Metal film 4.32k Ω \pm 1% 1/2W
R114	RN14BK2H2611F	Metal film 2.61k Ω \pm 1% 1/2W
R115	RN14BK2H1741F	Metal film 1.74k Ω \pm 1% 1/2W
R116	RN14BK2H1241F	Metal film 1.24k Ω \pm 1% 1/2W

SCHEMATIC SYMBOL	PARTS NO.	DESCRIPTION
R117	RN14BK2H9310F	Metal film 931Ω ±1% 1/2W
R118	RN14BK2H7150F	Metal film 715Ω ±1% 1/2W
R119	RN14BK2H5760F	Metal film 576Ω ±1% 1/2W
R120	RN14BK2H5111F	Metal film 5.11kΩ ±1% 1/2W
R121, 122	RN14BK2H4870F	Metal film 487Ω ±1% 1/2W
S101 a, b	J25-2822-04	MISCELLANEOUS Printed circuit board
	S01-1504-04	Rotary switch

P.C. BOARD

X75-1050-00

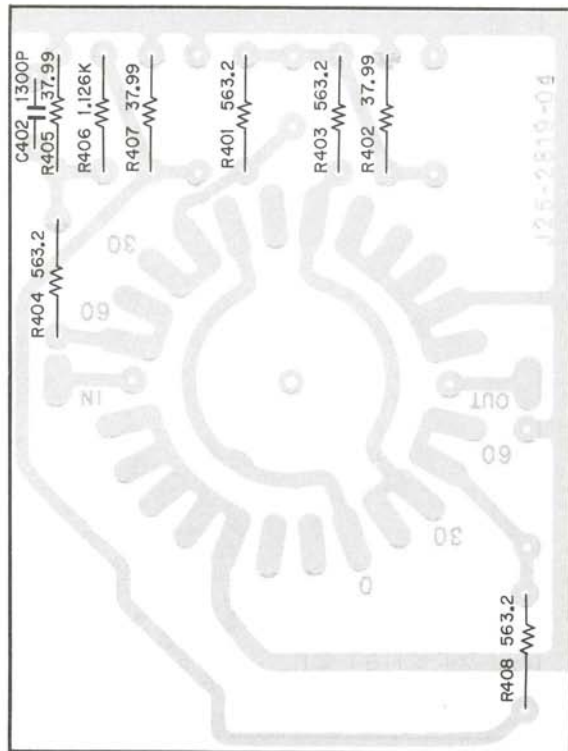

X75-1060-00

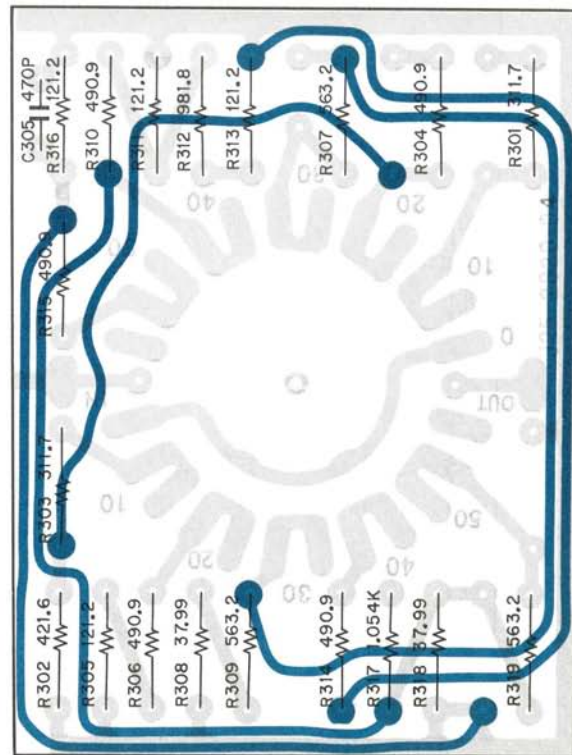

P.C. BOARD

X75-1070-00

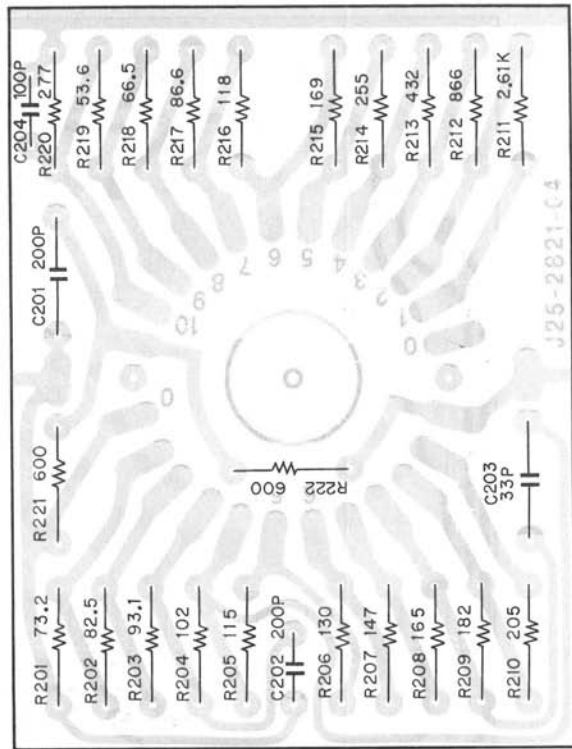

X75-1080-00

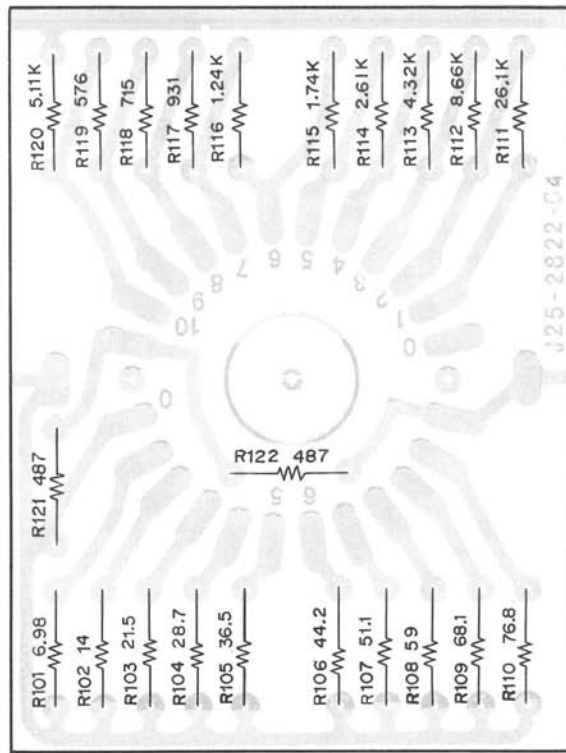

SCHEMATIC DIAGRAM

* Specifications and design are subject to change without notice for improvement.

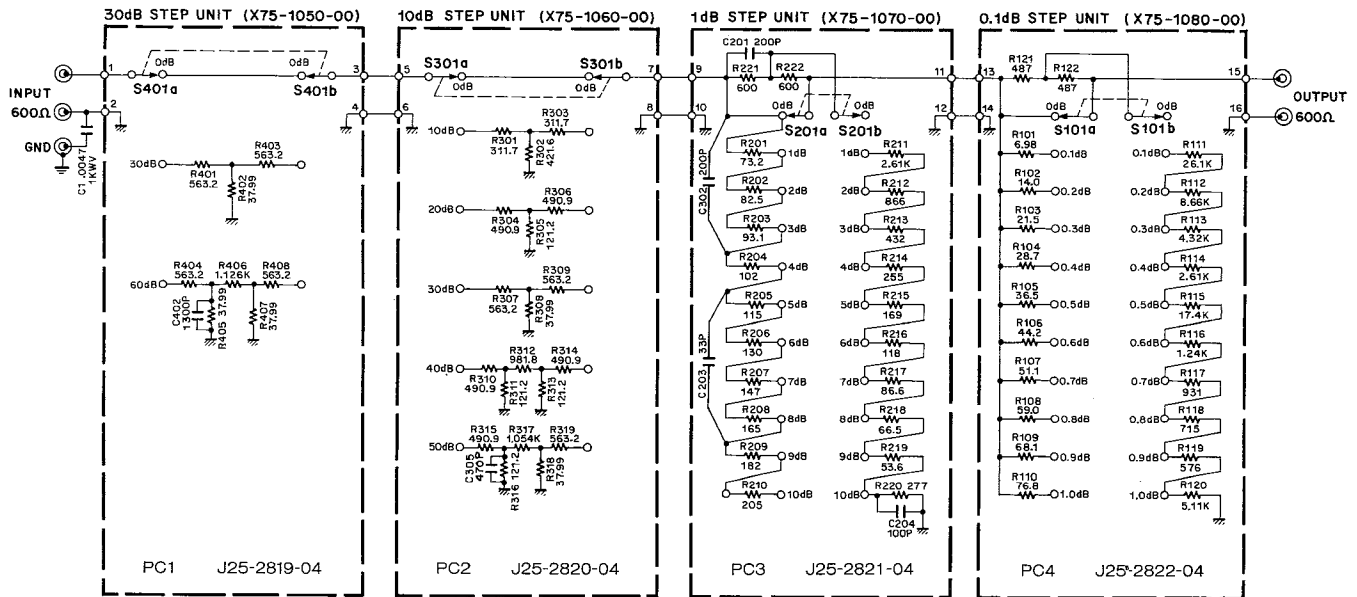

RA-920

A product of
KENWOOD CORPORATION

2-5, 1-Chome, Shibuya, Shibuya-ku, Tokyo 150, Japan

© 26410 PRINTED IN JAPAN B50 - 2828 - 20 (K)